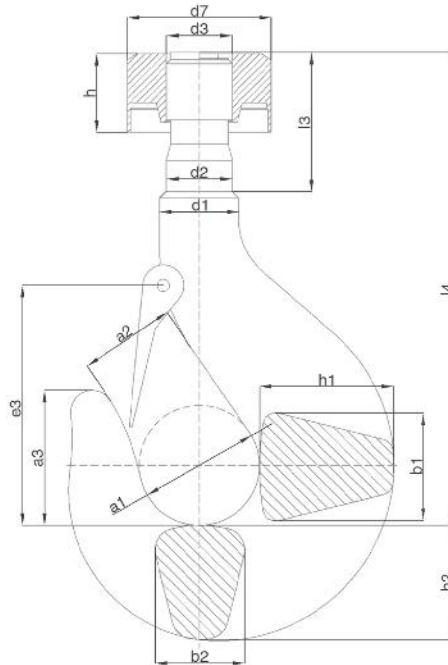

1.1 SHANK HOOKS BASED ON EN13001-3-5:2016
1.1.1 SINGLE FORGED HOOKS BASED ON RECOGNIZED EUROPEAN DESIGNS
1.1.1.1 Single forged hooks based on DIN15401 design
1.1.1.1.2 Machined fitted with nut

- WLL: from 5t to 2.000t.
- Hook and Nut FORGED, HEAT TREATED and thread fully MACHINED as per DIN15403 design.
- Material: carbon, alloys and super alloys. Stainless steels available upon request.
- Mechanical properties: P, S, T, V, W.
- Safety Factor: min. 4:1 with the highest material grade.
- Load Test: requested / recommended.
- Certificate: EN10204-3.1. For 3.2, ILO-3, FAT or Breaking Test available upon request.

SINGLE FORGED HOOKS BASED ON DIN15401 DESIGN | MACHINED FITTED WITH NUT

No	OVERALL DIMENSIONS (mm)													DIN 15413 Nut		Weight kg
	a1	a2	a3	b1	b2	d1	e3	h1	h2	d2 h11	d3	l3	l4	d7	h	
2,5	63	50	72	53	45	42	132	67	58	36	M36	83	250	70	44	7,4
4	71	56	80	63	53	48	148	80	67	42	M42	93	281,5	80	49	10,3
5	80	63	90	71	60	53	165	90	75	45	M45	103	314,5	95	56	14,4
6	90	71	101	80	67	60	185	100	85	50	Rd50x6	112	375	115	60	20,7
8	100	80	113	90	75	67	210	112	95	56	Rd56x6	122	413	125	67	28,8
10	112	90	127	100	85	75	221	125	106	64	Rd64x8	135	446	145	76	40,9
12	125	100	143	112	95	85	252	140	118	72	Rd72x8	157	504,5	165	87	65,4
16	140	112	160	125	106	95	280	160	132	80	Rd80x10	170	576	175	91	90
20	160	125	180	140	118	106	330	180	150	90	Rd90x10	187	645	185	102	130
25	180	140	202	160	132	118	360	200	170	100	Rd100x12	207	716	205	113	184
32	200	160	225	180	150	132	400	224	190	110	Rd110x12	232	788	240	131	254
40	224	180	252	200	170	150	447	250	212	125	Rd125x14	257	885	270	144	361
50	250	200	285	224	190	170	485	280	236	140	Rd140x16	280	969	320	153	502
63	280	224	320	250	212	190	550	315	265	160	Rd160x18	322	1100	360	181	700
80	315	250	358	280	236	212	598	355	300	180	Rd180x20	357	1245	400	198	1007
100	355	280	402	315	265	236	688	400	335	200	Rd200x22	402	1388	445	228	1417
125	400	315	450	355	300	265	750	450	375	225	Rd225x24	465	1565	490	246	2026
160	450	355	505	400	335	300	825	500	425	250	Rd250x28	510	1761	530	274	2846
200	500	400	565	450	375	335	900	560	475	280	Rd280x32	613	2012	590	343	3862
250	560	450	635	500	425	375	980	630	530	320	Rd320x36	690	2272	680	383	5411
320	630	500	715	560	475	425	1080	710	580	370	Rd360x36	780	2565	760	433	7620
400	710	560	755	630	530	475	1195	800	630	415	Rd400x36	875	2878	865	482	10441

Tolerances: -0/+7% forging tolerance. Machined tolerances as per DIN15403 design.
 Modifications: Shank length (L). Further dimensions upon request.