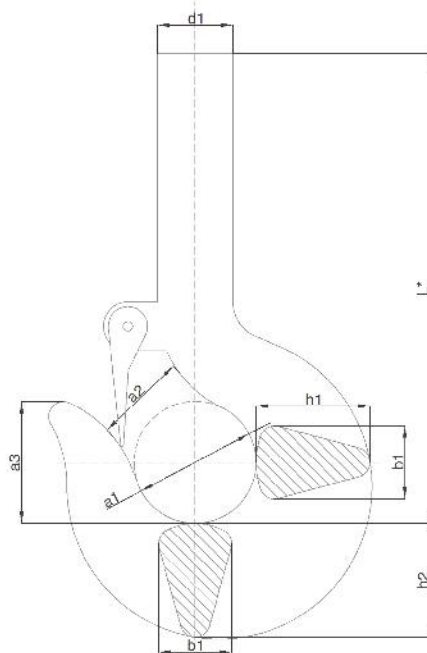

**1.1 SHANK HOOKS BASED ON EN13001-3-5:2016**
**1.1.1 SINGLE FORGED HOOKS BASED ON RECOGNIZED EUROPEAN DESIGNS**
**1.1.1.2 Single forged hooks based on BS2903:1980 design**
**1.1.1.2.1 Unmachined**

- WLL: from 5t to 250t.
- Hook FORGED and HEAT TREATED. Machining recommended to perform by manufacturer.
- Material: carbon, alloys and super alloys. Stainless steels available upon request.
- Mechanical properties: P, S, T, V, W.
- Safety Factor: min. 4:1 with the highest material grade.
- Load Test: requested / recommended after machining.
- Certificate: EN10204-3.1. For 3.2, ILO-3, FAT or Breaking Test available upon request

SINGLE FORGED HOOKS BASED ON BS2903:1980 DESIGN   UNMACHINED									
OVERALL DIMENSIONS (mm)									Weight
No	a1	a2	a3	b1	d1	h1	h2	L*	Kg
B5	65	49	65	39	38	60	60	253	5
B6,3	73	55	73	44	44	68	68	285	6,5
B8	83	62	84	50	50	77	77	318	10
B10	92	69	92	55	55	86	86	380	14
B12,5	103	77	104	62	60	96	96	418	19
B16	117	88	117	70	65	109	109	452	27
B20	131	98	132	79	75	122	122	510	38
B25	146	110	146	88	85	136	136	582	53
B32	159	119	160	95	90	148	148	653	69
B40	173	130	173	104	105	161	161	724	91
B50	191	143	191	115	115	178	178	796	121
B63	205	154	205	123	125	191	191	796	154

Tolerances: -0/+17% forging tolerance.

Modifications: Shank length (L). Further dimensions upon request.